

**• General Description**

The ZM095N03S combines advanced trench MOSFET technology with a low resistance package to provide extremely low  $R_{DS(ON)}$ .

**• Features**

- Advance high cell density Trench technology
- Low  $R_{DS(ON)}$  to minimize conductive loss
- Low Gate Charge for fast switching
- Low Thermal resistance

**• Application**

- DC/DC Converters in Computing, Servers
- Isolated DC/DC Converters in Telecom and Industrial
- POL application
- BLDC Motor driver

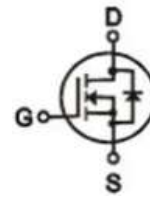
**• Product Summary**

$V_{DS} = 30V$

$R_{DS(ON)} = 9.7m\Omega$

$I_D = 10A$

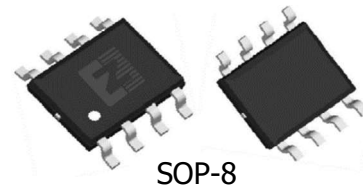
**• Ordering Information:**

Part NO.	ZM095N03S
Marking	ZM095N03
Packing Information	REEL TAPE
Basic ordering unit (pcs)	4000

**• Absolute Maximum Ratings ( $T_C = 25^\circ C$ )**

Parameter	Symbol	Rating	Unit
Drain-Source Voltage	$V_{DS}$	30	V
Gate-Source Voltage	$V_{GS}$	$\pm 20$	V
Continuous Drain Current <sup>②</sup>	$I_{D@TC=25^\circ C}$	10	A
	$I_{D@TC=75^\circ C}$	7.6	A
	$I_{D@TC=100^\circ C}$	6.3	A
Pulsed Drain Current <sup>①</sup>	$I_{DM}$	20	A
Total Power Dissipation <sup>②</sup>	$P_D@TC=25^\circ C$	3.4	W
Total Power Dissipation	$P_D@TA=25^\circ C$	0.69	W
Operating Junction Temperature	$T_J$	-55 to 150	$^\circ C$
Storage Temperature	$T_{STG}$	-55 to 150	$^\circ C$
Single Pulse Avalanche Energy@L=0.1mH	$E_{AS}$	31	mJ
Avalanche Current@L=0.1mH	$I_{AS}$	25	A

**•Thermal resistance**

Parameter	Symbol	Min.	Typ.	Max.	Unit
Thermal resistance, junction - case <sup>②</sup>	R <sub>thJC</sub>	-	-	36	° C/W
Thermal resistance, junction - ambient	R <sub>thJA</sub>	-	-	180	° C/W
Soldering temperature, wavesoldering for 10s	T <sub>sold</sub>	-	-	265	° C

**•Electronic Characteristics**

Parameter	Symbol	Condition	Min.	Typ	Max.	Unit
Drain-Source Breakdown Voltage	BV <sub>DSS</sub>	V <sub>GS</sub> =0V, I <sub>D</sub> =250uA	30			V
Gate Threshold Voltage	V <sub>GS(TH)</sub>	V <sub>GS</sub> =V <sub>DS</sub> , I <sub>D</sub> =250uA	1.2		2.5	V
Drain-Source Leakage Current	I <sub>DSS</sub>	V <sub>DS</sub> =30V, V <sub>GS</sub> =0V			1.0	uA
Gate- Source Leakage Current	I <sub>GSS</sub>	V <sub>GS</sub> =±20V, V <sub>DS</sub> =0V			±100	nA
Static Drain-source On Resistance	R <sub>DS(ON)</sub>	V <sub>GS</sub> =10V, I <sub>D</sub> =8A		9.7	12	mΩ
		V <sub>GS</sub> =4.5V, I <sub>D</sub> =6A		13	18	mΩ
Forward Transconductance	g <sub>FS</sub>	V <sub>DS</sub> =10V, I <sub>D</sub> =5A		9		s
Source-drain voltage	VSD	I <sub>S</sub> =10A			1.28	V

**•Electronic Characteristics**

Parameter	Symbol	Condition	Min.	Typ	Max.	Unit
Input capacitance	C <sub>iss</sub>	V <sub>DS</sub> =25V f = 1MHz	-	560	-	pF
Output capacitance	C <sub>oss</sub>		-	81	-	
Reverse transfer capacitance	C <sub>rss</sub>		-	49	-	

**Gate Charge characteristics(T<sub>a</sub>= 25°C)**

Parameter	Symbol	Condition	Min.	Typ	Max.	Unit
Total gate charge	Q <sub>g</sub>	V <sub>DD</sub> =15V	-	10.5	-	nC
Gate - Source charge	Q <sub>gs</sub>	I <sub>D</sub> = 8A	-	2.8	-	
Gate - Drain charge	Q <sub>gd</sub>	V <sub>GS</sub> = 10V	-	1.6	-	

Note: ① Pulse Test : Pulse width ≤ 300μs, Duty cycle ≤ 2% ;

② Device mounted on FR-4 substrate PC board, 2oz copper, with thermal bias to bottom layer 1inch square copper plate;

Fig.1 Gate-Charge Characteristics

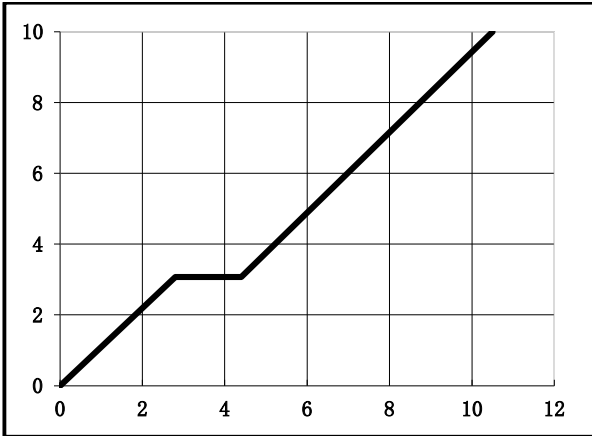

Fig.2 Capacitance Characteristics

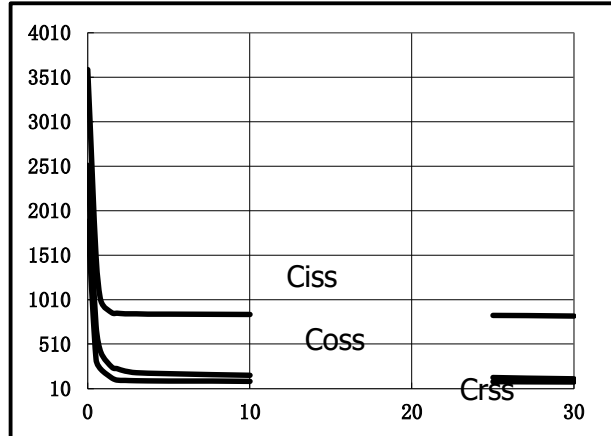

Fig.3 Power Dissipation Derating Curve

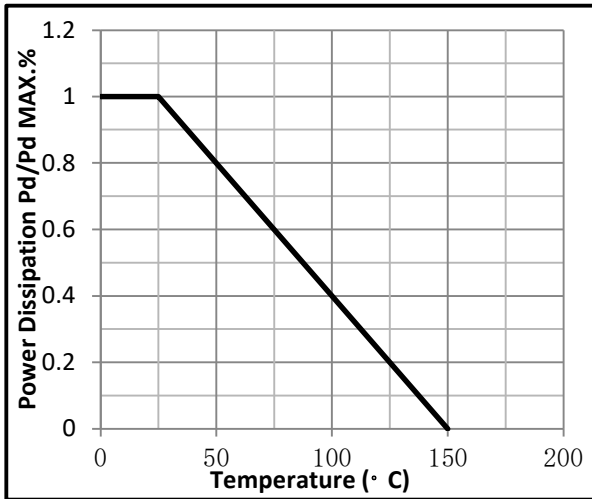

Fig.4 Typical output Characteristics

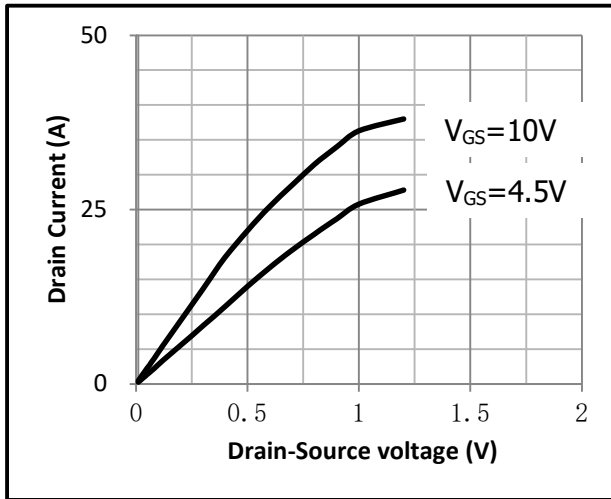

Fig.5 Threshold Voltage V.S Junction Temperature

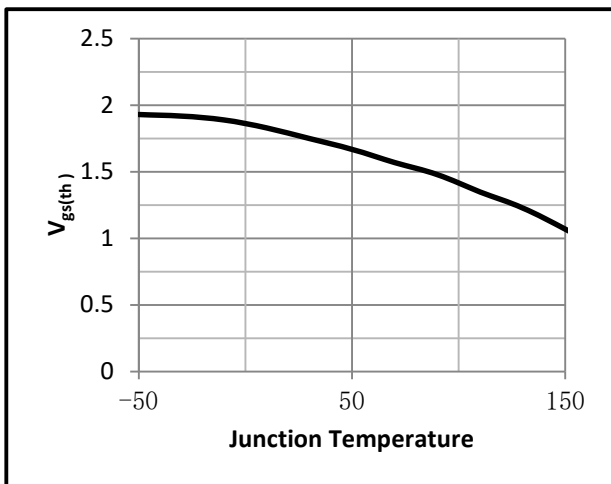

Fig.6 Resistance V.S Drain Current

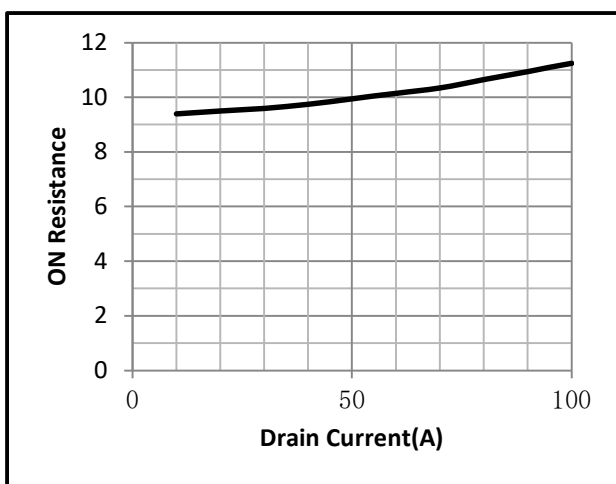

Fig.7 On-Resistance VS Gate Source Voltage

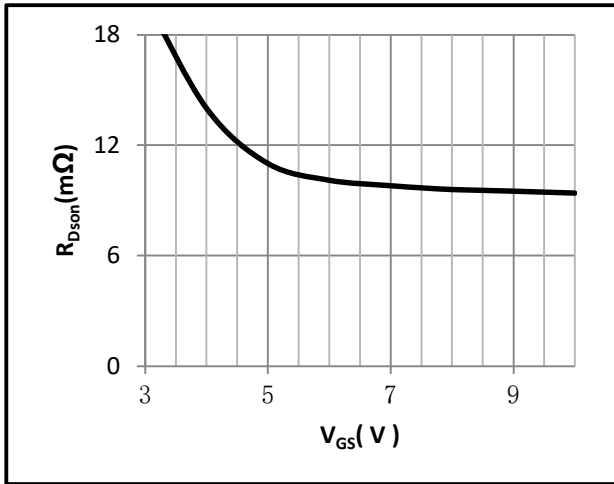

Fig.8 On-Resistance V.S Junction Temperature

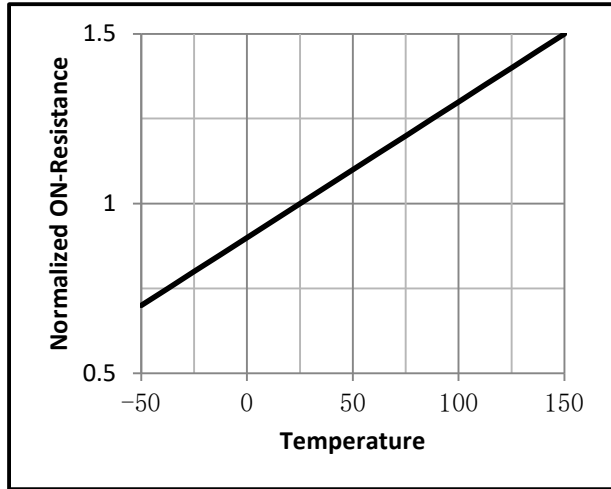

Fig.9 Gate Charge Measurement Circuit

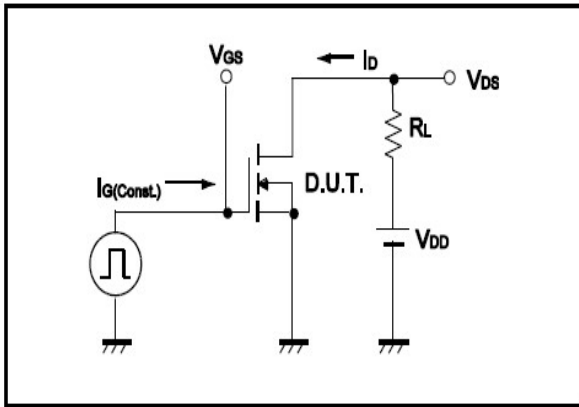

Fig.10 Gate Charge Waveform

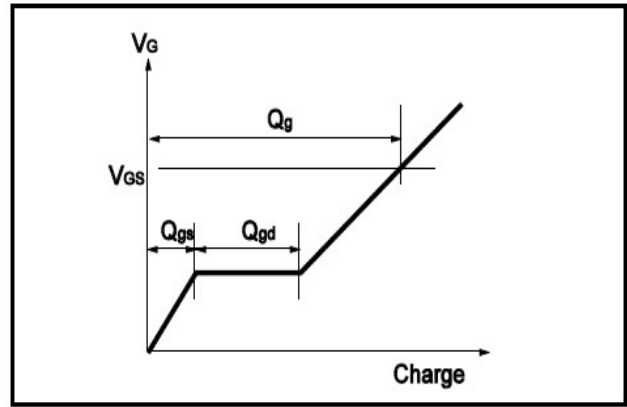

Fig.11 Switching Time Measurement Circuit

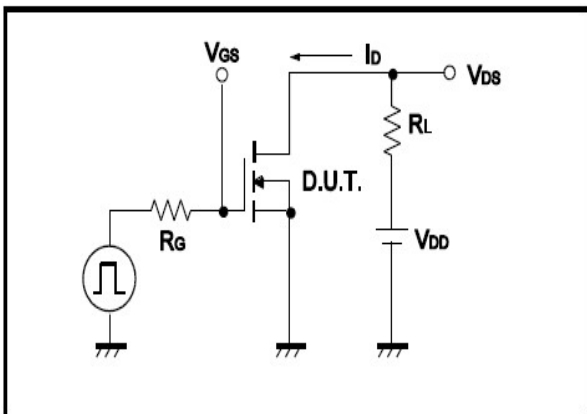
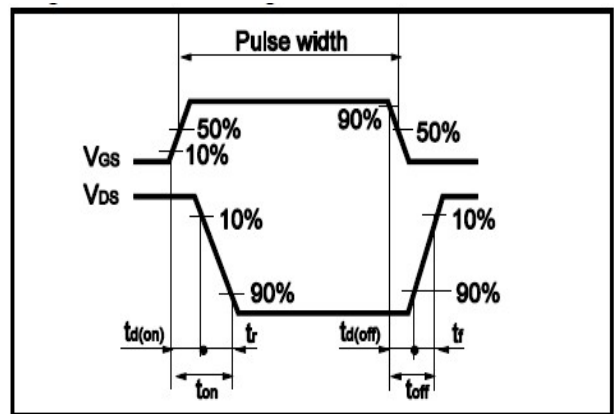

Fig.12 Switching Time Waveform





•Dimensions(SOP8)

Unit: mm

SYMBOL	min	TYP	max	SYMBOL	min		max
A	4.80		5.00	C	1.30		1.50
A1	0.37		0.47	C1	0.55		0.75
A2		1.27		C2	0.55		0.65
A3		0.41		C3	0.05		0.20
B	5.80		6.20	C4	0.19	0.20	0.23
B1	3.80		4.00	D		1.05	
B2		5.00		D1	0.40		0.62

